

PUBLIC



IST R&D. FP6-Priority 2.
SPECIFIC TARGETED RESEARCH PROJECT
Project Deliverable

Doc Number	SUIT_285
Project Number	IST-4-028042
Project Title	SUIT
Deliverable Nature	Report
Deliverable Number	D7.1.2
Contractual Delivery Date	31.1.2007
Actual Delivery Date	5.3.2007
Title of Deliverable	Plan for using and dissemination/exploiting knowledge
Contributing Workpackage	WP7
Dissemination Level	PU
Author(s)	Eli Sofer (RUNCOM), A. Zistler (IRT), Gavrilesco Augustin (IBBT), Robbie de Sutter (IBBT), Erwan Le Bras (Vitec), Francesc Enrich (URL), Francesc Pinyol (URL), Víctor Domingo (URL), Gabriel Fernandez (URL), N. García (UPM), Antonio Navarro (IT).

Abstract

Dissemination and Technology Uses is the business case foundation for Mobile BWA enhanced scalable video delivery techniques to be developed within the framework of the EC IST-4-028042 project SUIT. The main objective of this Deliverable is to prepare the Dissemination activities, including the contributions to standardization, to specify Exploitation plans for the project results namely patent submissions, and the production of the Technology Implementation Plan (TIP) Preliminary exploitation plans of the industrial and academy partners involved are presented and some forecasts are made by end user (business and consumer) in as an accurate way as possible. SUIT plays an important role, not only because of its technical merits but also due to its bandwidth efficient techniques based on scalable video techniques that would immensely improve delivery of media-rich content, interactive DTV and video streaming applications and have the potential to improve Broadcasters, Operators and ISP's operational performance.

Keyword list: Technology Implementation Plan (TIP); Dissemination; Exploitation.

PUBLIC

Plan for using and dissemination/exploiting knowledge
(Dissemination and Technology Uses)

SUIT_285

Executive Summary

The objective of this deliverable is to report the collective activity of partners to WP7 which is dedicated to the Dissemination and Technology Exploitation of assets developed within the framework of SUIT project. Furthermore, it is to make the project results available to the wireless and mobile community of researchers and technical experts, to promote dissemination of project results in the relevant international forums and attend international workshops and conferences, to participate and contribute in the appropriate standardisation bodies and to identify and design the promotion activities.

This deliverable as other D7.1x deliverables should be regarded as a living document , thus frequent revisions are expected in order to reflect the latest market trends, dissemination and exploitation activities of the SUIT consortium. Each partner has a strong motivation and commitment for distributing information about the project and its results to targeted groups and assess impact of the project in terms of improvement of competitiveness and creation of market opportunities for the partners.

The main objective of this deliverable is to document the Dissemination activities carried out within the reporting period, including the contributions to standardization.

The deliverable includes brief description of plans for the dissemination of knowledge to be carried out during project lifetime and will be the subject for further detailed elaboration in next revisions of the Deliverable. Future revisions will detail partners dissemination strategies, the targeted groups and the strategic impact of the project in terms of improvement of competitiveness or creation of market opportunities for the partners.

Also mentioned in brief, in this deliverable, the exploitation plans of the results for the consortium as a whole, or for individual participants. The detailed exploitation plans, or more specifically the Technology Implementation Plan (TIP) of each participant will be provided as a separate deliverable (D7.4) at the end of the project. Contribution to standardization activity will be the subject for an additional deliverable (D7.3) which will include all the work devoted to the packaging and presentation, as well as the attendance of important standardization bodies meetings, namely MPEG, IEEE802.16/WiMAX, WWRF and DVB.

The TIP will have to describe the participant's actual achievements in dissemination and their plans at that time for the exploitation of their results. The conclusions are also to be submitted to publication and presentation as scientific papers.

This deliverable will cover tasks performed for the dissemination of the project results, including: WEB-site, workshop, publications in conferences and magazines, demonstrations, liaison with other projects for sharing of technical results. The workshop will be organized towards the end of the project. The dissemination of the simulation results will be made through the organization of a public workshop on this subject. This activity will serve as the basis for the dissemination of selected SUIT project findings and knowledge. Participations at Fairs and exhibitions will be explored for the exploitation of the project's results. Depending on the decision within the SUIT consortium for the type of information to be made publicly known, this task also includes preparation of marketing material (brochures, WWW pages) for supporting the promotion of the project. A web site has been established from the start of SUIT activity and will provide appropriate relevant information about the progress of the project.

While the project proceeds, results from various SUIT WPs will be selected and evaluated by WP7 and respective exploitation plans will be conceived, by either individual partners or by the consortium in its entirety.

Market overview

Mobility is the fastest growing segment in the global telecommunication market. Subscribers value the freedom, immediacy, ease-of-use and power of mobile communications. Mobile broadband has emerged as the latest mobile service and it is poised for growth over the next decade.

The market for mobile broadband is still taking its first steps. Service availability is limited, subscribers often do not have a true broadband experience, and the cost of service is too high. However, the increasing penetration of laptops, PDAs and other data-centric devices is creating a strong propensity to use and pay for mobile broadband services. In many developed countries, data now accounts for 20% to 30% of mobile carrier revenues and this share is rapidly growing, whereas voice revenues are stagnant.

Most of the growth will be driven by personal broadband services, which go beyond basic cellular data services and make available the functionality of wired broadband in a mobile environment. Applications and services available at home and in the office will be available everywhere. A more widely available broadband access will encourage work productivity, personal communications and entertainment on the go. New services and applications that are specifically suited to mobile usage scenarios will also appear and new usage scenarios emerge. As with the transition of voice communications from fixed lines to mobile phone, the broadband connection ceases to be tied to a location and becomes a personal service.

The Internet has pushed the television to a new era, that of interactivity. However, the main difference between them is the amount of bandwidth required by the second to transport TV/Video signals with good QoS. Mixing the internet protocol and a broadcasting network (BN) may not result in an acceptable interactive system. Moreover, BNs are unable to serve mobile users moving at high speed. SUIT will explore several techniques to minimize the above mentioned problems and will propose solutions in the context of the universal interactive television access and network convergence. SUIT will consider an end-to-end chain composed of a playout, last mile networks, and terminals of different computational and display capacities.

Firstly, video contents, either live or pre-recorded will be encoded in a scalable way to be delivered simultaneously to a variety of devices from HD flat displays to handheld devices.

Secondly, as the viewer expects that the interactive system responds to a request quickly, SUIT will optimally manage at the playout, the DVB-T/H and WiMAX resources, thereby, the requested content will be delivered as fast as possible through the available TDMA/FDMA slots in both networks. As SUIT is using scalable video contents, the playout system is able to increase, for short time, the bandwidth to support high priority contents, e.g. hyperlinked interactive video contents.

Thirdly, scalable multiple descriptions, possibly unbalanced, are delivered through DVB-T/H and WiMAX in order to support high speed mobility. To achieve the objectives related to scalable video, SUIT will make use of the most recent technologies like scalable MPEG-4 AVC/H.264 and MPEG-21 DIA. The former will allow encoding digital video contents in a scalable manner. In order to optimally meet the network conditions, joint source-channel-modulation schemes will be investigated. Finally, the latter will support terminal descriptions and negotiations between the terminal and the playout.

Table of Contents

1	INTRODUCTION.....	8
1.1	SUIT DEFINITION.....	8
1.2	TECHNICAL CHARACTERISTICS OF SUIT.....	8
2	MARKET ANALYSIS.....	10
2.1	MARKET TRENDS.....	10
2.1.1	<i>The Broadband Wireless Access Market.....</i>	<i>10</i>
2.1.2	<i>Mobile WiMAX.....</i>	<i>11</i>
2.1.3	<i>New Devices and Applications.....</i>	<i>14</i>
2.1.4	<i>Mobile Internet Development.....</i>	<i>14</i>
2.2	BROADBAND WIRELESS ACCESS MARKET OPPORTUNITIES.....	16
2.2.1	<i>Mobile DTV.....</i>	<i>16</i>
2.2.2	<i>Intensive Data Applications Dominate the Wireless Service Mix.....</i>	<i>16</i>
2.3	MARKET DRIVERS.....	17
2.3.1	<i>Mobile and Fixed Wireless Access Applications.....</i>	<i>17</i>
3	SERVICE/PRODUCT DEFINITION.....	18
3.1	BUSINESS APPLICATIONS.....	18
3.2	RESIDENTIAL (NON BUSINESS) APPLICATIONS.....	18
4	COMMERCIAL IMPLEMENTATION RISK ANALYSIS.....	20
5	DISSEMINATION STRATEGY.....	21
5.1	CONSORTIUM DISSEMINATION STRATEGY.....	21
5.2	EXPLOITATION AND DISSEMINATION ACTIVITIES.....	23
5.2.1	<i>Activity 7.1 - Dissemination of results.....</i>	<i>23</i>
5.2.2	<i>Activity 7.2- Contributions to Standardization.....</i>	<i>25</i>
6	EXPLOITATION STRATEGY.....	26
6.1	INDIVIDUAL EXPLOITATION STRATEGY FOR PARTNERS.....	26
6.2	UNIVERSITIES/RESEARCH CENTRE EXPLOITATION.....	29
6.3	ACTIVITY 7.3: EXPLOITATION PLANS:.....	31
7	CONCLUSIONS AND FUTURE PLANS.....	33

List of abbreviations & symbols

All-IP	= All-Internet Protocol
AVC	= Advanced Video Communication
ARPU	= Average Revenue Per User
BWA	= Broadband Wireless Access
CC/PP	= Composite Capabilities/Preferences Profile
COST	= European Co-operation in the Field of Scientific and Technical Research
CTC	= Convolutional Turbo Coding
DVB-T	= Digital Video Broadcasting-Terrestrial
DVB-T/H	= DVB-T/Handheld
DVB-RCT	= DVB- Return Channel Terrestrial
ETSI	= European Telecommunications Standards Institute
FEC	= Forward Error Correction
FMO	= Flexible Macroblock Ordering
FPGA	= Field Programmable Gate Array
FTP	= File Transfer Protocol
FWA	= Fixed Wireless Access
HD	= High Definition
HDTV	= High Definition Television
HO	= Hand_Over
IBBT	= Interdisciplinair Instituut voor Breedband Technologie Vzw
IEEE	= Institute of Electrical and Electronics Engineers
IRT	= Institut für Rundfunktechnik GmbH
IPR	= Intellectual Propriety Right
ISP	= Internet Service Provider
IT	= Instituto de Telecomunicações
IT++	= Information Theory in C++
ITU	= International Telecommunications Union
ITU-R	= International Telecommunication Union Radiocommunication Sector
JVT	= Joint Video Team
LDPC	= Low Density Parity Check
MCTF	= Motion-Compensated Temporal Filtering
MD	= Multiple Description
MDC	= Multiple Description Coding
MD-SVC	= Multiple Description-Scalable Video Coding
MHP/IPTV	= Multimedia Home Platform/ Internet Protocol Television
MMR	= Monthly Management Reports
MPEG21-DIA	= Moving Picture Experts Group 21 Digital Item Adaptation
MPEG AVC	= MPEG Advanced Video Coding
OFDM	= Orthogonal Frequency Division Multiplexing
OFDMA	= OFDM Access
PB	= Project Board
QAM	= Quadrature Amplitude Modulation
RF	= Radio Frequency
QoS	= Quality of Service
R&S	= Rohde & Schwarz
RTP/RTCP	= Real-time Transport Protocol/ RTP Control Protocol
RTSP	= Real Time Streaming Protocol
RUNCOM	= Runcom Technologies Ltd
SDC	= Single Description Coding
SDP	= Session Description Protocol
SDPng	= Session Description Protocol (New Generation)
SIP	= Session Initiation Protocol

MPEG-21 DIA-UED	= Moving Picture Experts Group 21 Digital Item Adaptation – Usage Environment Description
SoC	= System on Chip
SVC	= Scalable Video Coding
TIP	= Technology Implementation Plan
UHF	= Ultra High Frequency
UPA	= Unequal Power Allocation
UPM	= Universidad Politécnica de Madrid
UniS	= The University of Surrey
URL	= Universitat Ramon Llull Fundacio Privada
VITEC	= SA VITEC
WAVECOM	= WAVECOM - Soluções Rádio, Lda
WiFi	= Wireless Fidelity
WiMAX	= Worldwide Interoperability for Microwave Access
WISP	= Wireless Internet Service Providers
WLAN	= Wireless Local Area Network
WP	= Workpackage

1 INTRODUCTION

1.1 SUIT Definition

SUIT is well positioned to take advantage of the new era of convergence between Broadcast and Telecommunication ushering new generation of Broadband Wireless Systems and DVT delivery systems, utilizing innovative broadband OFDM/OFDMA access technologies. The most profound revolution is the transition from Fixed Internet to Mobile Internet and enormous number of Mobile subscribers which has exceeded, by now, the number of the fixed subscribers. The huge demand for Multimedia, video streaming and interactive applications, on the move, and the need for reliable, efficient use of the spectrum and just the required bandwidth for each specific application will offer to SUIT partners excellent business opportunities. It is expected that Internet and interactivity will be integrated into television. The DVB-MHP, DVB-RCT are examples of such convergence. Nevertheless, there are several drawbacks at the lower layers of the OSI reference model. The terrestrial broadcasting network DVB-T is not able to cope with mobility at least at high speed due to inter-carrier interference. Instead of adding a new level of channel coding as followed by DVB-H with the resulting delay increasing, SUIT proposes a different strategy.

The main idea is to combine in a fruitful manner DVB-T with the broadband wireless access network IEEE802.16e providing a low round-trip delay and robust communications at high mobile speed, above 150 km/h. In this context of network convergence, broadband networks like DVB-T/H and Mobile WiMAX will certainly play an important role, delivering multimedia data namely compressed video to fixed and mobile subscribers. There is a strong movement towards convergence at multiple levels and particularly in view of potential efficiency gains obtained from integration. Therefore, convergence goes through integration of services, networks, systems, platforms and terminals. However, an efficient end-to-end content delivery through heterogeneous networks and terminals requires a serious and deep research in order to guarantee an acceptable QoS.

The other main idea in SUIT is to broadcast and stream scalable and, if necessary, multiple descriptive visual contents in an optimal way through DVB-T/H along with IEEE802.16 (WiMAX) networks to homes and to extended home environments.

The QoS (delay and bandwidth) will also be guaranteed by the intelligent multiplexer at the playout site and by requesting appropriate bit rate and spatio-temporal layers from the scalable servers and live encoders. The proposed novel system will deliver multimedia data to users, including broadcasting, multicasting and unicasting under the big umbrella well known as all-IP.

SUIT is an applied research project. Therefore, an experimental demonstration will be setup and the performance will also be tested with a MHP like application.

1.2 Technical characteristics of SUIT

SUIT will propose solutions in the context of the universal interactive television access and network convergence. SUIT will consider an end-to-end chain composed of a playout, last mile networks, and terminals of different computational and display capacities.

Main Objectives

- To include and promote scalable video (SVC), namely advanced scalable video coding technology in broadcasting networks in Europe;
- To overcome bandwidth fluctuations (QoS) caused by indoor channels and terminals. In SUIT, this is achieved by video scalability as a natural tool for the optimal dynamic

adaptation of the video stream to the user preferences and available bandwidth at any instant of time;

- To enable robust communications for high speed mobile terminals;
- To define adaptive joint source and transmission techniques for optimal network resources allocation so as to take advantage of the source scalability and the last mile wireless channel conditions by transmitting at high source data rates (lower channel code rate) under good network conditions, while reducing source data rates in bad network conditions.
- To develop and implement Resource Management algorithms at the playout, enabling QoS provisioning and service differentiation for IP-based (DVB-T/H and WiMAX) networks for seamless integration of broadcast, multicast and unicast transmissions;
- To design intelligent multiplexers to support with priorities (QoS) scalable video streams and to accommodate streamed unicast video contents along with broadcasting contents and Internet data;
- To promote fast video-interactivity and to ensure low round-trip delay in broadcasting networks;
- To explore scalable multiple-description coding for error-resilient layered communications over hybrid broadband networks (DVB-T/H+WiMAX);
- To introduce High Definition TV transmission over hybrid broadband networks.
- To contribute to the creation of 4G network, IP-based, running at as high as 100Mbps while mobile and 1Gbps when fixed and support next generation applications such as multimedia services including high definition television to the user terminals anywhere and anytime;
- To identify relevant QoS parameters for HDTV transmission over hybrid network maintaining a certain QoS level;
- To use rate-distortion-power surfaces to develop a novel power optimized Multiple Description Coding algorithm for scalable video (AVC/H.264 or wavelet based). The use of the rate-distortion-power surfaces in the development of novel Unequal Power Allocation (UPA) to video sub-carriers will reduce co-channel interference, hence enabling an increase in the number of video channels that can be broadcasted. Alternatively, it can enable wider WiMAX cell coverage. No specific work will be carried out related to DRM, conditional access and content production. However, the system architecture will be designed considering the possibility to deploy existing content protection systems.

2 Market Analysis

2.1 Market Trends

2.1.1 The Broadband Wireless Access Market

Telecommunications markets worldwide are undergoing immense change due to rapid technological progress leading to the introduction of new products and services, deregulation and privatisation. In the effort to satisfy increasing consumer demand for advanced services beyond basic telephony, both established and emerging service providers are now under intense competitive pressure.

Internet technologies and applications have grown more rapidly than anyone could have envisioned even five years ago, opening up brand new modes of communication, collaboration and coordination between consumers, businesses and trading partners. The Web has quickly culminated into a myriad of highly sophisticated hardware and software applications that are enabling forward thinking companies to leverage the massive and ubiquitous public technology infrastructure of the Internet to create new value for their stakeholders.

Today, service providers (incumbent telecommunications companies with a fixed network) are faced with several dilemmas. While the current telephone networks were designed to handle average phone calls of a few minutes in length, the growth of the Internet has created a class of users who stay on the line for an average of several hours. What are now called "old world" voice networks were certainly not designed to handle a future characterised by the convergence of data, voice and video. Old world hierarchical systems with many layers and end-to-end connections accessed through a dial-tone delivery fall far short of the universal capabilities that a converged multiservice network can provide. Transporting data already takes up almost half of the service providers' bandwidth, yet generates less than twelve percent of their revenues. Moreover, the cost of deploying new bandwidth is dropping by a factor of ten each year, while price competition is cutting service margins to extremely thin levels. The result is increasingly lower rates of return from investments in the network infrastructure.

The next business challenge in the new millennium for Broadcasters and Internet Service Providers (ISPs) is to explore and define new revenue sources from the existing and emerging telecommunications infrastructure.

This unprecedented demand is forcing service providers to discard old concepts and business models and adopt New World business models that rely on the network infrastructure to deliver multiple services over the Internet and Video Broadcast delivery networks. No company can rely on one method of transporting the information from service providers to reach new customers that were not accessible with traditional techniques and expand the available services to existing ones. With the deployment of wireless network services providers will benefit from:

- **Improved Revenue Opportunities:** fixed and mobile broadband wireless systems can install quickly and provide services in urban and under-served areas in substantially less time than wireline alternatives.
- **Differentiated Services:** high deep mobile broadband scalable services such as Internet access and combined data, voice and video are now possible in non-traditional wireless markets.

As demand for information, entertainment and communications explodes, a broadband fixed wireless network presents the single best medium for delivering these services reliably, cost-effectively, and profitably. In fact studies propose that the cost for deployment of Mobile broadband wireless networks is the lowest of all currently available transport streams and has the potential to provide connectivity solutions to new areas in significantly less time. Technology advances in wireless modulation and coding techniques enable wireless links to provide the scalable multi-megabit services needed to meet today's requirements.

Communication companies all over the world are struggling to meet this exciting new demand for services. To succeed in the next five years, providers must react now by installing flexible, scalable networks that meet today's requirements and are designed to support the emerging new world broadband wireless packet-based services that scale with the customers need to grow.

Therefore communications companies need to develop and roll out new systems that will support present and future needs for connectivity. Broadband fixed wireless solutions provide a major step forward to meet these needs.

The range of potential services is limited only by the needs of the customers. The networking industry is in a state of a rapid transition from the old-world model based on closed systems providing a single product offering – data – to a new world driven by the need for multiple combined formats such as voice-over-IP (VoIP) with high speed two way data and video services. The required levels of quality mandated by good business practices requires that certain standards be maintained to ensure that the interleaving of services does not distract from the usability of the information.

The start of SUIT project activity has come in most suitable timing that could exert its impact in shaping the way how rich-media content are deployed efficiently utilizing technological assets of SUIT in the area of scalable video coding and application of effective adaptive-rate channel coding and full suit of new scalable descriptive real time encoders, gateways and combining matrices.

2.1.2 Mobile WiMAX

The market for mobile broadband is still taking its first steps. Service availability is limited, subscribers often do not have a true broadband experience, and the cost of service is too high. However, the increasing penetration of laptops, PDAs and other data-centric devices is creating a strong propensity to use and pay for mobile broadband services. In many developed countries, data now accounts for 20% to 30% of mobile carrier revenues and this share is rapidly growing, whereas voice revenues are stagnant.

Most of the growth will be driven by personal broadband services, which go beyond basic cellular data services and make available the functionality of wired broadband in a mobile environment. Applications and services available at home and in the office will be available everywhere. A more widely available broadband access will encourage work productivity, personal communications and entertainment on the go. New services and applications that are specifically suited to mobile usage scenarios will also appear and new usage scenarios emerge. As with the transition of voice communications from fixed lines to mobile phone, the broadband connection ceases to be tied to a location and becomes a personal service.

The current cellular infrastructure will not be able to cope with the growing amount of traffic generated by high-speed and real-time applications. To meet the demand for wireless broadband over the next decade, mobile operators and other service providers have to explore new approaches when planning for next generation networks, and to adopt new technologies that enhance the existing infrastructure or create a more advanced one.

Mobile WiMAX is the technology best suited to meeting the demand for personal broadband services. It offers advanced security, Quality of Service (QoS), and worldwide access through a simple interface. Service providers also benefit from the low costs that a technology based on open standards, vendor interoperability, and favorable IPRs allows.

There is a strong case for mobile and fixed carriers, greenfield operators and other service providers to adopt mobile WiMAX to meet subscriber demand for personal broadband services. WiMAX has several performance and cost advantages over competing technologies and fits well into the current wireless ecosystem. It offers a compelling business opportunity that many service providers worldwide are carefully assessing or have already embraced. Those service providers that are committed to providing the best possible service to their subscribers cannot afford to leave WiMAX out of their roadmap to fourth generation networks.

There are many reasons to deploy mobile WiMAX and, although some may resonate more with some service providers than with others, they are all crucial ingredients to induce mass adoption of end-user devices and widespread infrastructure deployments. The WiMAX Forum has identified four key areas in which WiMAX has a strong advantage over other wireless technologies:

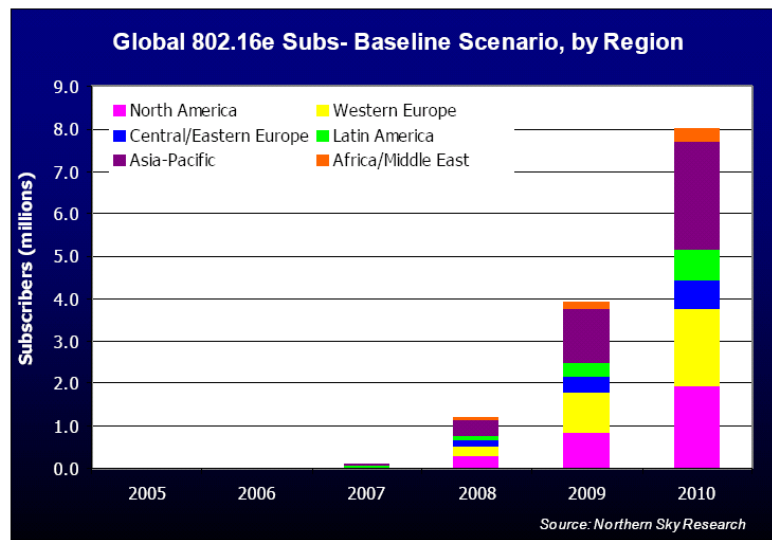

1. Superior performance

WiMAX meets all the requirements for mobile access. It supports multiple handoff mechanisms, ranging from hard handoffs (with break-before-make links) to soft handoffs (with make-before-break links), power saving mechanisms for mobile devices, advanced QoS and AAA functionality, and low latencies.

The advanced performance of mobile WiMAX is largely tied to its use of Orthogonal Frequency Division Multiplexing Access (OFDMA), a multiplexing technique that transmits downlink and uplink traffic using parallel carriers organized in sub-channels. OFDMA gives network operators greater flexibility in managing spectrum resources and leads to an enhancement of indoor coverage and of the throughput of mobile devices. It also allows a higher spectral efficiency compared to 3G cellular technologies and Wi-Fi.

WiMAX relies on Scalable OFDMA (SOFDMA), a version of OFDMA that keeps the spacing of sub-carriers constant, by changing the number of sub-carriers in a given channel width.

OFDMA has clearly emerged as the technology of choice for next generation mobile networks and looks set to replace CDMA- and WCDMA-based solutions eventually.

WiMAX performance is further enhanced by the use of Time Division Duplex (TDD) instead of the Frequency Division Duplex (FDD) used in 3G networks

2. Flexibility

WiMAX was designed from the ground up to be an all-IP technology that is optimized for high-throughput, real-time data applications and that is not beholden to a legacy infrastructure. This approach has not only brought improved performance but also, perhaps just as importantly, give service provider increased flexibility in harnessing the technology to offer established or emerging new services and to work with the spectrum resources available.

3. Advanced IP-based architecture

WiMAX is a next-generation technology that supports the best of today's functionality and that will facilitate the cellular operators' transition to all-IP networks and to fourth generation technologies. Cellular networks are also moving towards an IP core and new wireless interfaces, but progress is slow partly because the legacy infrastructure does not allow an easy migration. The IP core

network in WiMAX is also attractive to greenfield operators, as it is less complex and less expensive to deploy and operate.

WiMAX fully supports IMS functionality to enable service providers to offer compelling advanced voice and data applications. Both wired and wireless service providers are increasingly committed to adopting IMS, and IMS will become a core network structure that works across technologies and that facilitates their integration

As an IP-based technology, WiMAX fits easily into an ecosystem of multiple wired and wireless technologies. No single technology will be able to meet the rapidly growing and increasingly sophisticated demand for broadband data and voice connectivity in any location and on any device. The ability to integrate different technologies into their networks is one of the largest challenges that service providers will face over the next few years. WiMAX will help operators make the complex transition from networks dominated by a single air interface (GSM/UMTS or CDMA) to an ecosystem where different technologies seamlessly interoperate and provide access using a single interface. SUIT promotes the convergence between WiMAX and DVB-H and therefore will make them as interoperable as possible by using the concept of all-IP as described above.

4. Attractive economics

WiMAX aspires to be the first mobile broadband technology that meets mass-market demand for cost-effective, high-throughput wireless services. With 3G, the high cost of the infrastructure has resulted in high prices that effectively limit adoption to business users that are not very price-sensitive. The business market segment is limited in size and the true opportunity for service providers is to reach the wider market that includes consumer users. WiMAX lower costs and improved performance allow service providers to widen the appeal of their service offering by increasing the bandwidth available to each subscriber and by lowering the price of the service.

The business case for WiMAX is quite compelling as the cost of the equipment is kept very low by a combination of interoperable components based on open standards, mass adoption of subscriber units, an attractive IPR structure, and high base station capacity.

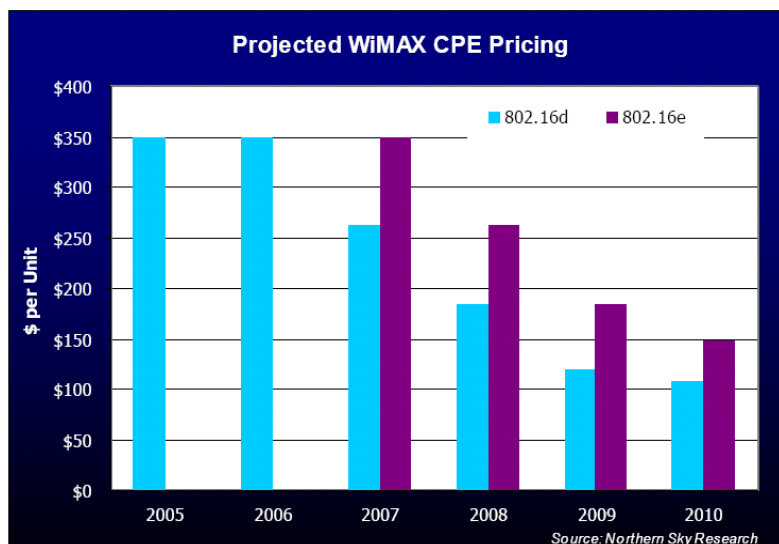

2.1.3 New Devices and Applications

The superior economics and performance of WiMAX, coupled with its flexibility and next-generation architecture, are on their own strong arguments in favor of WiMAX adoption. Even more compelling, however, are the new devices and applications that WiMAX will encourage to emerge. The combination of high-throughput, low latency and QoS functionality makes WiMAX suited to any mobile device, from laptops to PDAs, ultra-compact PCs and other data-centric devices, game consoles, smartphones, and other cellular phones

Other real-time applications, like video and audio streaming, and gaming, will greatly benefit from QoS and low latency. They will become increasingly important as new devices optimized for these applications are introduced. Broadcast is another potential WiMAX application. Work is currently under way within the WiMAX Forum to add support for it by reserving part of the existing transmission channel for broadcasting applications. In this context, SUIT will play the right role.

WiMAX will generate additional revenue streams from four main sources:

An increase in ARPU (Average Revenue Per User) among existing subscribers, as they add new services to their plan (e.g. personal broadband in a bundled offer from a DSL or cable modem provider, or as an add-on to a mobile voice contract).

A higher number of subscribers, as WiMAX will address the demand of the consumer market segment that is difficult to meet cost-effectively with a 3G network. The reduction in customer acquisition costs due to the lower device subsidy cost will make it possible for Service Providers to be more aggressive in attracting new subscribers.

Churn reduction, as mobile broadband access is perceived as a valuable additional service that ties in the customer and provides a powerful differentiating factor against competing service providers.

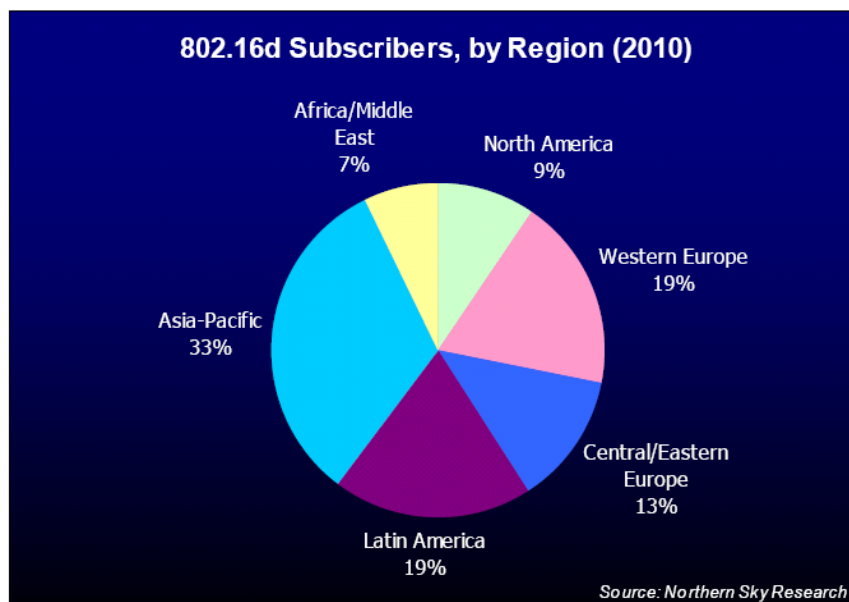

2.1.4 Mobile Internet Development

As is the case in the fixed-line telephony market, where data was the fastest-growing segment of telecom services, fixed and mobile Broadband Wireless is becoming increasingly important medium for data and multimedia transmission. Consumers, both private and business, increasingly value the ability to access data and video on the move. The largest impediment of low or moderate transmission speed has been removed by the advent of true Broadband wireless Access Systems such as WiFi and Mobile WiMAX, Interactive TV (DVB-RCT) and video delivery systems (DVB-

T/H) which offer a significant upgrade of transfer speeds. These recent technological advances lead us to believe that the long-term data revenue opportunity for cellular operators is tremendous. This is also the business opportunity for SUIT partners to become significant players of offering a full range of BWA equipment and enhancement tools and variety of devices.

The outstanding success of the IP standard protocol, upon which the Internet is based, with its flexible and cost-effective packet-based approach for transmitting information, has proved to be the key to leveraging a single network for carrying data, voice and video, accessible anywhere, at any time, for anyone. A unified, IP-based network that integrates data, voice and video opens the door to an incredible wealth of applications that will make people more productive and businesses more competitive – all by increasing efficiency, saving time and dramatically reducing costs. The multiservice network combines data, voice and video traffic into a single, intelligent network – a reliable, secure and scalable environment that companies can leverage as a strategic business asset and consumers as a complete communication platform. The multiservice network is therefore poised to make a major impact on both the business and the consumer global arenas and this is where developments are leading to, today.

The tremendous success of the Internet can be attributed to several factors (i.e. declining costs, growth in PC penetration, development of services and content, competition) and the growth is self-supporting. Broadly speaking, the Internet generates revenues for a number of different groups of players:

- infrastructures suppliers (delivering revenues from supply of the Internet hardware, software and expertise)
- pure telecom operators (from providing access to Internet service providers (ISPs) for the end users as well as backbone connectivity for the ISPs)
- ISPs (from providing access to Internet, advertising, e-commerce and content fees)
- Product suppliers and content providers (utilising the Internet as a 'distribution' channel)
- Telecoms are benefiting from the growth of Internet in a number of ways. Provided the right strategic choices are made, the Internet development is likely to have a profoundly beneficial effect on telecom operators. They are well positioned to benefit by:
 - providing backbone connectivity and hosting to ISPs
 - providing Internet access to the end users
 - developing their own ISPs, exploiting brand names and customer ownership
 - diversifying into content provision utilising the synergies of a fully vertically integrated Internet business.

The overall market growth accelerates once a critical mass has been achieved. At this stage growth drivers begin to leverage each other, rapidly removing all possible bottlenecks. It is estimated that by now European Internet market already passed this phase in its development, while it is only a question of time before we see the same trend in emerging Europe (Central & Eastern European countries).

An ability to judge the amount of future corporate bandwidth requirements is of extreme importance for the long-term success of the Internet as a viable tool. Network providers must be able to supply enough capacity to meet the growing amount of IP-based traffic in corporate networks. It is estimated that the bandwidth requirements will increase by a factor of 50 to 100 times over the next seven years. Initially, the largest increase will come from corporate usage. Business-to-business Internet usage will be responsible for about 55% of all bandwidth requirements in the developed world and 66% in the developing world from the beginning of 2000. But the deployment of ever-faster access devices for consumers will lead to a rapid increase in residential demand for capacity.

2.2 Broadband Wireless Access Market Opportunities

Broadband access solutions are rapidly emerging as important competitive enablers for communicators in the global telecommunications market place. Demand for increased bandwidth to support the delivery of new services is at an all time high. Driven by deregulation, telecommunications markets worldwide are undergoing intense competitive pressures. Broadband wireless offers both established and emerging service providers a quick and cost-effective way to enter the local access market, with solutions and technologies designed to meet today's demand for the delivery of data, voice and high speed Internet services, as well as tomorrow's demand for enhanced digital telephony, video and multimedia services.

The demand for cost-effective delivery of multiple communication and broadband services over resilient broadband networks is growing at a staggering rate. Further, broadband wireless is fast becoming a key network access technology for the delivery of new data, Internet, voice, video and multimedia applications to homes and businesses.

Global networks are converging - voice and data, wireless and wireline - forming consolidated, cost-effective, packet-based networks that are easier to manage, maintain, and modernize. "Cable, wireless and DSL promise to transform the Internet. They will let people watch films and broadcasts, conduct two-way video conferences and make phone calls." (Andrew Backover, Denver Post, Jan. 24)

To prove the point, the numbers of global broadband access subscribers by technology are sketched out in the figure that follows (by Pioneer Consulting).

2.2.1 Mobile DTV

Mobile TV services see significant, if not spectacular, take-up and usage. The vast majority of TV and video viewing continues to take place in the home, delivered by traditional broadcasting platforms (e.g. direct-to-home satellite, terrestrial broadcasting and cable), with strong take-up seen in emerging IPTV services. Integrated operators offering fixed IPTV services seize the opportunity to offer converged TV and video services, using their mobile platforms to enhance the IPTV experience (for example, using mobile video clips to advertise programmes and provide brief programme excerpts). With a proliferation of videoplayback devices featuring large-capacity hard disks, many people download TV and video content (including films, conventional broadcast TV programmes and Web-hosted videos) using high-speed fixed Internet connections at home, for subsequent viewing while mobile.

2.2.2 Intensive Data Applications Dominate the Wireless Service Mix

Following years of slow growth in data revenue (other than from person-to-person messaging) 3G-based mobile TV and video services see strong take-up, as customers are attracted by streamed services offering a large number of channels at relatively affordable prices (similar to those offered by Orange in France and the UK early in 2006). Mobile TV and video services account for 13% of total ARPU by 2012, as shown in Figure 5.1.

WiMAX deployment by leading mobile operators accelerates its progress to global economies of scale for infrastructure and terminals. Relatively low investment costs and the availability of relatively cheap WiMAX spectrum encourages the entrance of WISP (Wireless Internet Service Providers) in many markets, many of which focus on providing regional services.

2.3 Market Drivers

2.3.1 Mobile and Fixed Wireless Access Applications

The demand for Broadcast and BWA services will be driven by more than just the need for greater competition in the local loop. There will be a number of key applications that will drive BWA services, including:

- **High-speed Internet.** The other main application driving FWA services will be high-speed Internet access -- the ability to surf the Web and download files at a faster rate than that offered by the standard dial-up modem. This will be more of a driver in those countries that have a relatively high penetration of Internet usage, such as in Scandinavia.
- **Digital and/or interactive TV.** Some of the operators that have applied for licenses in some countries are actually those organizations that provide or are planning to provide interactive or digital TV services. The FWA portion of the service would be the bearer network for Internet access on the TV or interactive services, such as shopping or information services. The ability to interact with broadband content will drive the usage of FWA integration with the digital or interactive TV set-top box.
- **High-bandwidth telecoms and ISP`s value-added services (VAS).** These include:
True unified multimedia messaging services will require a higher-speed data connection than that offered by a standard dial-up modem, as the user may be transferring or downloading large audio files or watching streaming media. As more users become interested in this type of service, the demand for broadband services will grow, and BWA (Mobile WiMAX, DVB-RCT, WiFi, DVB-T/H) can offer the broadband access methods that will benefit.

Thus, new revenue opportunities emerge through expanded broadband fixed services for service providers. Service providers have a unique opportunity to generate revenues from new services in the residential, business and education markets by expanding capabilities with broadband fixed and mobile wireless solutions. The current access mediums such as enhanced copper, cable and fibre competently serve only a portion of available market and, with the exception of fibre, provide insufficient symmetrical bandwidth to meet multi-megabit needs of the current broadband fixed market – much less allow for future data speeds.

3 Service/Product Definition

Towards identifying the services that would make SUIT a successful potential product, the possible Application Categories have to be defined first. We examine two types of categories. The first addresses the commercial needs of the Business sector while the second the needs of the Residential sector. SUIT is in a good position to support the below mentioned services.

3.1 *Business Applications*

Imaging

Imaging applications are used to transferring images usually of high quality/resolution. Examples of Imaging applications are:

- Diagnostic imaging (e.g. Xray images)
- Video post production
- Computer Aided Drawings (CAD)

Such applications may require speeds in the order of 34 Mbps.

Information Exchange

These applications allow for exchanging any type of information, usually in non real time, between two or more locations

Typical examples of Information Exchange applications are:

- Remote Database and Computer File Access
- Document Interchange
- LAN to LAN interconnection

Collaboration

These applications allow for exchanging any type of information, usually in real time, between two or more locations.

Typical examples of Collaboration applications are:

- Video conference
- Audio conference
- Multimedia conference

E-Commerce

These applications are used for economic transactions between companies and their customers. These applications usually require a certain level of security. Examples of such applications are:

- Product information hosting
- Product Ordering
- Credit Card verification and charging
- Electronic Billing

3.2 *Residential (non Business) Applications*

ISP Access

This is obviously one of the most popular, relatively new, services where broadband infrastructure can offer great improvement. Examples of ISP access applications include,

- Web surfing
- Multimedia streaming
- Electronic shopping
- Electronic banking

Multimedia Entertainment

This category includes mainly broadcasting type of applications like:

- Broadcast video, audio and data
- Pay per view
- Near video on demand
- Video and audio on demand

Education

These applications are a mix of ISP access, Multimedia broadcasting and collaboration applications but they are addressed to a larger audience in the schools and homes. Examples of Education applications include:

- Broadcast video, audio and data
- Multimedia conference
- Web surfing

4 Commercial Implementation Risk Analysis

There exist potential risks that can be identified and assess their implications and explore proper measures which need to be taken in order to cope with those risks effectively, and ensure an appropriate level of confidence to encourage SUIT partners, individually or collectively, for further spending and entry to a full scale development for the commercialisation of SUIT developed technical assets by industrial partner .

The major drive and the main objective of SUIT project is the implementation and validation of a wide range of scalable video technologies endowing high reliability and cost effectiveness of rich-media content applications . SUIT advocates a new concept based on rather innovative and promising technology which, so far, has not been endorsed in emerging standards such as, HiperLAN2, ISDB-T, wireless LAN in the 5GHz (IEEE 82.11).

DVB-T standard, as the first standard based on OFDM, has been successfully implemented for Digital TV broadcast and UK was in the scene for the first wide deployment of DTT services covering installed base of DVB-T receivers in excess of 1 M.

In spite of this success, all indications point to a much slower introduction of digital terrestrial television in Europe, and commercial prospects appear less promising in many European countries, such as Sweden and Finland, notably due to much stronger cable and satellite distribution. The argumentation behind this slower pace of DTT proliferation in Europe is the non existing, so far, of a viable solution for DVB-T Up Link which has the potential to transform DTT into a highly interactive platform compatible to cable TV. The lesson drawn is that successful implementation does not ensure commercial success in a highly competing environment.

Identified risks facing SUIT commercial exploitation are the following:

- **Technology risks** - SUIT R&D plan presents a great technological challenge in a new field which will probably face other competing technologies. Technology risks resides in many areas, such as proper channel modelling and implementation of scalable encoding/decoding techniques and development of efficient gateways and Multiplexers. Developing effective algorithms to deal with channel impairments such as, interference and jamming environment in ISM bands. The risks exist, however the consortium`s partners are experts in diversified areas, and some have prior experience and expertise in developing innovative access technologies (OFDM and OFDMA based systems and DTV receivers (DVB-T/H). We believe that the consortium as a whole is well equipped to meet the challenge.
- **Market risks** - Many factors can impede penetration to the market:
 - SUIT should develop an appealing business strategy to convince Operators and Service Provider to integrate SUIT technological assets which could be the driver for cost reduction in deploying added value applications due to the efficient use of the spectrum and the resultant differentiation factors considered as good selling points.
 - Influence in shaping emerging standards: Full-scale exploitation of SUIT technological assets without ensuring some noticeable impact on emerging standards could pose some risk taking. SUIT industrial partners with support of academic partners have to realize the need for dedicated effort within relevant standards` bodies to ensure adoption of SUIT concept as a part the emerging standard to be developed within BRAN`s Sub 11 working group.
 - Market niches: SUIT consortium has to identify market niches and type of services most attractive in those identified niche markets. SUIT business case is best served and can gain a wide acceptance by potential customers if SUIT is proposed as an enhancement tools for deploying added value multimedia applications.
 - Strategic alliance: Penetration to market can be impeded without strategic co-operation with major telecom companies and Service Providers

5 Dissemination Strategy

5.1 Consortium Dissemination Strategy

The main objective of this WP is to prepare the Dissemination activities, including the contributions to standardization, to specify Exploitation plans for the project results namely patent submissions, and the production of the Technology Implementation Plan (TIP) deliverables.

This WP intends to support the preparation of the Dissemination and Exploitation plans. This includes the description of plans for the dissemination of knowledge gained during the work, and the exploitation plans of the results for the consortium as a whole, or for individual participants or group of participants. It should be expressed as much as possible in concrete terms, for instance, the dissemination strategies, the targeted groups and the strategic impact of the project in terms of improvement of competitiveness or creation of market opportunities for the partners. Another deliverable, to be written in the end of the project and based on the former, is the Technology Implementation Plan (TIP). The TIP must describe the participant's actual achievements in dissemination and their plans at that time for the exploitation of their results. Dissemination of the simulation results is made through the organization of a public workshop on this subject. The conclusions are also to be submitted to publication and presentation as scientific papers.

SUIT explicitly recognizes the importance of disseminating project results by allocating a specific WP for that mission which is divided into the following activities:

Activity 7.1: Dissemination of Results

Activity 7.2: Contributions to Standardization

Activity 7.3: Exploitation Plans

The objective is to make the project results available to the wireless and mobile community of researchers and technical experts, also to support the preparation of the dissemination and exploitation plans, the dissemination strategies, the targeted groups and the strategic impact of the project in terms of improvement of competitiveness or creation of market opportunities for the partners. Each partner has, for these reasons, a strong motivation and commitment for distributing information about the project and its results

The Dissemination activities includes the contributions to relevant standardization bodies, the preparation of Exploitation plans for the project results, namely, patent submissions, and the production of the Technology Implementation Plan (TIP) deliverables.

This deliverable, as a living document, will be updated on periodic basis once every six months and the second update will contain description of partners individual plans for the dissemination of knowledge gained during the work, and the exploitation plans of the results for the consortium as a whole. On SUIT Consortium level, the intention is to prepare a dissemination strategy and schedule dedicated events, during lifetime of the SUIT project, for the presentation of SUIT major results in workshops, seminar and exhibitions and allocate the resources needed for carrying out these tasks. The dissemination strategies towards well defined targeted groups, including broadcasters, Operators and ISPs, those who have the potential to grasp the strategic impact of the project in terms of improvement of competitiveness or creation of market opportunities for the customers as well as SUIT partners. Additional activity is dissemination of the simulation results which will be performed through the organization of a public workshop on this subject. The scientific and technical conclusions are also to be submitted to publication and presentation as scientific papers. Dissemination of the project results, includes: WEB-site, workshop, publications in conferences and magazines, demonstrations, liaison with other projects for sharing of technical results. An example for the later is the Concertation meetings.

SUIT has the following plan for paper publication (some of them have already been submitted for publication):

- 1-A. Navarro, SUIT- Scalable, Ultra-fast and Interoperable Interactive Television - (SUIT architecture as defined in the proposal).
- 2- P. Schelkens, Y. Dhondt, O. Guye, A. Navarro, R. Van de Walle, S. Warroll, Error-resilient Transmission of MPEG-4 SVC Streams over DVB-T/H and WiMAX Channels with Multiple Description Coding Techniques.
- 3- C. H. Liew, S. Worrall, M. A. Mota, M. Goldshtein and A. Navarro, Hybrid WiMAX and DVB-H Emulator for Scalable Multiple Descriptions Video Coding Testing.
- 4- J. Plaza, J. Cabrera, F. Jaureguizar, N. Garcia, A new class partitioned discrete model for the characterization of RTP multicast transmission through IEEE 802.11 channels.
- 5- C. H. Liew, J. Cabrera, J. Plaza, F. Jaureguizar, G. Narciso, IEEE802.11g Emulator for Scalable Video Coding Testing.
- 6- G. Fernandez, A. Navarro, F. Enrich, V. Domingo, F. Pinyol, An Advanced Playout Architecture for Delivering Two IP Scalable Video Descriptions.
- 7- A. Zistler, M. Probst, K. Vermeirsch, V. Domingo, Announce and Feedback Protocols Design for Scalable MDC Video over DVB-T/H and WiMAX.
- 8- J. Ferreira, P. Pratas, J. Cabrera, J. Plaza, F. Enrich, V. Domingo, A. Navarro, A DVB-T/H and WiMAX Platform for Broadcasting Scalable MDC of Video.
- 9- J. Lauterjung, A. Zistler, A. Navarro, M. Goldshtein, Handover and Delay Issues in the Context of IP Broadcasting over Convergent DVB-T/H and WiMAX Networks.

SUIT partners will be involved in IEEE ISCE 2008 organization and we intend to promote a special session on the convergence of mobile broadband networks, especially for broadcasting.

WP7 will prepare a study of the potential impact of SUIT results on improvement expected on reducing operational cost and performance enhancement that could be achieved by Service Providers who are seeking new revenue streams in order to continue to grow. Due to increased competition operators have to offer innovative services, that will address both residential (e.g. Multimedia on Demand) and business market sectors (e.g. E-commerce, Intranets). SUIT results will have profound impact in many aspects deemed as crucial to service Operators such as, efficient use of the spectrum, optimisation of bandwidth per application using proper video scaling method for each type of application and addressed end device. Most of the new services are expected to be based on IP packet oriented techniques.

A list of innovative services that are candidates for improvement utilizing SUIT technological assets is the following:

- Movies on Demand

- Teleshopping
- Near Video on Demand
- Delayed Broadcast
- Games
- Telework
- News on Demand
- Distance learning
- Videotelephony
- Home Banking
- Telemedicine
- Videoconferencing

5.2 Exploitation and Dissemination Activities

The following are the dissemination activities and contribution to the standards carried out by partners of SUIT during the reporting period.

Partners Involved

- Instituto de Telecomunicações (IT)
- Interdisciplinair instituut voor BreedBand Technologie Vzw (IBBT)
- Universitat Ramon Llull Fundacio Privado (URL)
- Rohde and Schwarz GmbH and Co Kommanditgesellschaft (R&S)
- The University of Surrey (UniS)
- SA VITEC (VITEC)
- Runcom Technologies Ltd (RUNCOM)
- Institut für Rundfunktechnik GmbH (IRT)
- Universidad Politécnica de Madrid (UPM)
- WAVECOM – Soluções Rádio, Lda (WAVECOM)

5.2.1 Activity 7.1 - Dissemination of results

This activity has developed the following actions:

IT:

- IT organized the 3rd International Workshop on Mathematical Techniques and Problems in Telecommunications (<http://www.mtpt.it.pt/>). Thus, SUIT supported this scientific event. Five tutorials were presented:
 1. CROSS-LAYER ISSUES IN WIRELESS NETWORKS, Vincent Poor.
 2. ENCRYPTION, Joachim Rosenthal.
 3. MATHEMATICAL NEEDS FOR BEHAVIOURAL MODELLING OF TELECOMMUNICATION CIRCUITS AND SYSTEMS, José Carlos Pedro.
 4. A MULTIOBJECTIVE ROUTING OPTIMISATION FRAMEWORK FOR MULTISERVICE NETWORKS - A HEURISTIC APPROACH, José Craveirinha.

5. JOINT SOURCE CHANNEL TURBO TECHNIQUES FOR WIRELESS COMMUNICATION, Christine Guillemot.

Two papers have been published:

- A. Navarro and V. Silva, "Fast Conversion between DCT and Wavelet Transform Coefficients," 3rd International Workshop on Mathematical Techniques and Problems in Telecommunications, Leiria-Portugal, Sept 4-8, 2006.
- B. Gabriel and A. Navarro, "Multi-carrier Optimization for Compressed Video Streaming," To appear in the IEEE Int. Conf. on Consumer Electronics, Las Vegas, Jan 10-13, 2007.
- Paper presentation in IEEE ICCE
- Participation in MPEG meeting- Marrakech
- Talk in a seminar organized by IT and R&S in Aveiro-Portugal: 70 attendees, mostly from operators and broadcasters.

IRT:

- Attendance at the WiMAX World Europe Conference (22nd to 24th May 2006) in Vienna and submission of an abridged report to the "Broadcast systems Management Committee" (BMC) - which is the broadcast systems research and development co-ordination platform within the EBU. Furthermore, the document has been forwarded to the Public Broadcasters of Germany, Austria, and Switzerland, as well as to the SUIT Consortium.
- Presentation at the "International Press Club of Munich" about WiMAX technique, the standards and information about the WiMAX license auction in Germany finished in December 2006. Another presentation held was focussing on WLAN techniques, trends and innovations.
- Presentation of SUIT-project to IRTs board of directors

IBBT:

- F. Verdicchio, A. Munteanu, A. Gavrilescu, J. Cornelis, and P. Schelkens, "Embedded Multiple-description Coding of Video," accepted for publication in IEEE Transactions on Image Processing, 2006.

URL:

Two papers have been presented in international conferences about DVB-H IP encapsulation and optimisation. URL has also been present with its own booth at the New Technology Campus of the International Broadcasting Convention, held in Amsterdam during September 2006, showing a demonstration of media and metadata delivery over IPTV and DVB-T/H networks using MPEG-21 technologies:

- A. López, G Fernández, "Efficient media delivery over mobile terminals using DVB-H," Proceedings of the 10th IEEE International Symposium on Consumer Electronics (ISCE 2006), pp: 357-362, July 2006, Saint Petersburg
- A. López, G Fernández, "Efficient IP encapsulation in a DVB-H platform," Proceedings of the International Broadcasting Convention, IBC 2006, pp: 132-139, Sept 2006, Amsterdam

UniS:

The error patterns and emulators have been demonstrated to visitors to UniS's labs. These visitors include a high level official from the UK Ministry of Defence, and a team of researchers from Hewlett Packard.

UPM:

- Dissemination of results to Spanish companies (telefonica I&D) and to Spanish administration authorities (Ministrei de Industria)
- Elaboration of the local SUIT web page

Runcom:

- A template for D7.1.2 was prepared and submitted to SUIT partners

5.2.2 Activity 7.2- Contributions to Standardization

This activity has developed the following actions:

IT:

- M. Santos, A. Silva, A. Navarro, "H.264 Deblocking Filter Implementation on a Virtex-II," ISO/IEC JTC1/WG11 Doc. M13620, Jul 2006.
- Navarro, "Crosscheck report on fixed-point DCT/IDCT algorithms," ISO/IEC JTC1/WG11 Doc. M13701, Jul 2006.
- Yury Reznik, Arianne Hinds and A. Navarro, "On Complexity Criteria and Metrics for MPEG Fixed-Point IDCT Standard," ISO/IEC JTC1/WG11 Doc. M13703, Jul 2006.
- M. Santos, A. Silva, A. Navarro, "MPEG-4 VLD+IQ+IDCT Implementation on a Virtex-II," ISO/IEC JTC1/WG11 Doc. M13139, April 2006.
- A. Silva, J. Tavares, A. Navarro, "MPEG-4 Testbed for Video IDCT Specification," ISO/IEC JTC1/WG11 Doc. M13140, April 2006.
- A. Silva, J. Tavares, A. Navarro, "MPEG-4 Test Results for Video IDCT Specification," ISO/IEC JTC1/WG11 Doc. M13141, April 2006.
- Arianne T. Hinds, Yuriy A. Reznik, Phoom Sagetong, Honggang Qi, Siwei Ma, Antonio Navarro, "MPEG-4 Test Results for Video IDCT Specification," ISO/IEC JTC1/WG11 Doc. M13311, April 2006.

RUNCOM:

- Attending IEEE802.16e working group meetings on March, May and July 2006.
- Attending IEEE802.22 workgroup meetings and submitting 3 contributions on OFDMA based PHY layer. The meeting were held on March, May, July and early Sept 06. Those three contributions are :
 1. "Deployment scenarios with reuse1", Eli Sofer, Peretz Shkalim, Moti Goldstein, IEEE 802.22 Wireless RAN, June 2006.
 2. "OFDMA Single Channel Parameters", Eli Sofer, Ramon Khalona, Wendong HU, IEEE.802.22 Wireless RAN, June 2006.
 3. "SuperFrame and PHY Single Channel". Eli Sofer, Doron Ezri, Zion Hadad IEEE802.22 Wireless RAN August 2006.
 - "OFDMA single Channel Harmonization" Eli Sofer, Yossi Segal, doron Ezri, Michael Erlichson, IEEE802.16.22, 11 February 2007

6 Exploitation Strategy

6.1 Individual Exploitation Strategy for Partners

For the manufacturers involved in the SUIT consortium, exploitation of the project results offers a key strategic opportunity for short-, mid-, and long-term development of their telecom business, both in Europe and globally.

The manufacturers are already active in some standards bodies (e.g. DVB and WiMAX) and SUIT will offer a framework to transform this investment and participation into a substantial commercial opportunity on the time frame of 2008 - 2012.

SUIT offers the opportunity to build worldwide market share if the project achieves its goals. The experience gained in this project will directly influence the Enhanced WiMAX and DVB-T networks and the network quality. Furthermore the experience will be used for better product planning and cost reduction. The SUIT project will provide recommendations for WiMAX deployment. This will provide growth in the WiMAX and DVB-T /DVB-H markets and thus bringing benefit to the entire European mobile telecommunications industry.

The results of the SUIT project, both the enhancement techniques in the form of algorithms and systems and the implementation of those in the simulators and playouts, in conjunction with the new resource management techniques, can be used to contribute to the standardization bodies, to improve our products in terms of performance and costs and to design a more efficient and cost effective deployment of those products. This applies to the manufacturers of the consortium (VITEC, RUMCOM and R&S). The know-how gained within this project will also be promoted towards the industrial activities of them to design and develop next generation end-to-end broadband fixed and mobile solutions and hence into product development and commercialization. We should remind the impact of SUIT technologies may have in our society.

R&S

R&S expects to gain significant experience from the work in the project on DVB test and measurement applications in different environments. The combination of DVB-T/H and WiMAX is likely to emerge over the next two years as a solution for coverage problems or lack of frequency resources in urban environments. With the knowledge that can be gained from extended trials, R&S will be in a position to develop a product that combines testing of DVB-T/H and WiMAX signals and testing the interactivity (handover) between both systems.

VITEC

VITEC will stand in the continuation of already done research efforts made at a French level with the RIAM COPARO project that has enable to define and develop a first multi-DSP electronic board used for real-time encoding of SDTV programmes under the H.264/AVC format and at an European level the currently running EUREKA ITEA MAGELLAN project where MPEG-2 to H.264 transcoding and transrating tools were developed. VITEC Multimedia aims at improving its technology in real-time video coding and extending the application field of its coders. As a seller of video components, VITEC Multimedia is particularly interested by standard technology and more particularly by the MPEG family. VITEC Multimedia has started the development of a DSP-based family of video multiprocessor platforms and is expected to be able to soon propose to customers an advanced platform enabling to encode HDTV live content. Demonstrative results will be shown during international commercial fairs like IBC and NAB and it will allow one to evaluate the market for such technologies.

RUNCOM

RUNCOM regards collaboration in SUIT project with other partners as an unique opportunity for future commercial exploitation of OFDMA technology which is poised as a promising candidate for nextG cellular mobile systems. The implications of the adaptive multi access OFDM (OFDMA) are profound which signifies a paradigm shift opening new business opportunities for operators, service providers, system-on-chip and equipment manufacturers. Runcom will exploit the tangible results of SUIT together with other industrial and academic to commercialize technology assets developed with the project and reach mature products in the following areas:

1. Runcom will exploit results and develop a converged dual mode system-on-chip combining 16e chip (WiMAX Chip) and DVB-T chip thus extending reach of the two converged networks;
2. Runcom plans to use technological assets developed in SUIT project towards integration of MIMO with the Base Station serving p-t-mp system. Such product could take the form of a module in such a system sold to OEM's manufacturers.

Runcom regards collaboration in SUIT with other partners as a unique opportunity for further future commercial exploitation of the OFDMA technology which has been accepted as the basis for IEEE802.16, Mobile WiMAX and the new IEEE802.22 standard in the making phase. The implications of the OFDMA are profound in opening new business opportunities for broadcasters, broadband communication service providers and telecommunication companies in introducing new broadband access technology (OFDMA).

Runcom participation in the development of the adaptive OFDMA baseband and the Wireless DLC is in line with its strategic goals and mainstream future planning for the development of a highly survivable and affordable two way broadband communication system capable of offering a wide range of services (Video, data and VoIP) to business and private customers.

Runcom has definite plans to exploit the tangible results of SUIT together with other industrial partners and invest further efforts and resources beyond the scope of SUIT project to commercialise technology assets and reach mature products in the following areas:

Runcom will transfer the modem in its FPGA implementation to ASIC targeted to systems operating in Unlicensed ISM bands. The "modem on chip" will support the deployment of low cost broadband access systems operation in hostile environment where jamming and interference are expected from other systems sharing the same frequency band. The modem will utilize adaptive modes and other powerful anti-jamming strategies to be developed within the project.

Runcom intends to introduce more enhancements on the second development of "modem on chip" where OFDMA will be employed as the access scheme, enabling additional level of adaptivity through the dynamic allocation of sub-carriers within the same OFDM symbol to different users. This level of adaptivity can be equally applied to broadband wireless access systems operating in TDD or FDD modes. The OFDMA modem will serve as the essential building block for two main emerging markets- Interactive DVB-T systems where the Uplink will employ several operational modes based on OFDMA access scheme. Runcom is part of the RCT working group preparing the recommendation for standard for the DVB-T Return Channel. The recommendation for standard will be submitted to the DVB-Technical Module on September 2000, and hopefully will be approved early 2001. The Up link will support deployment of a wide range of added value multimedia services, and thus facilitate the convergence of broadcast and telecommunication OFDMA has become very popular and well acknowledged as the promising technology with the potential of offering superior performance in NLOS conditions relative to single frequency.

Other potential markets for exploitation of SUIT results relate to mobile video surveillance using Mobile WiMAX high capacity on the Uplink where multiple users can upload their video images from the scenes to a command centre such as Police Headquarter or Medical Services Centre, see below pictures

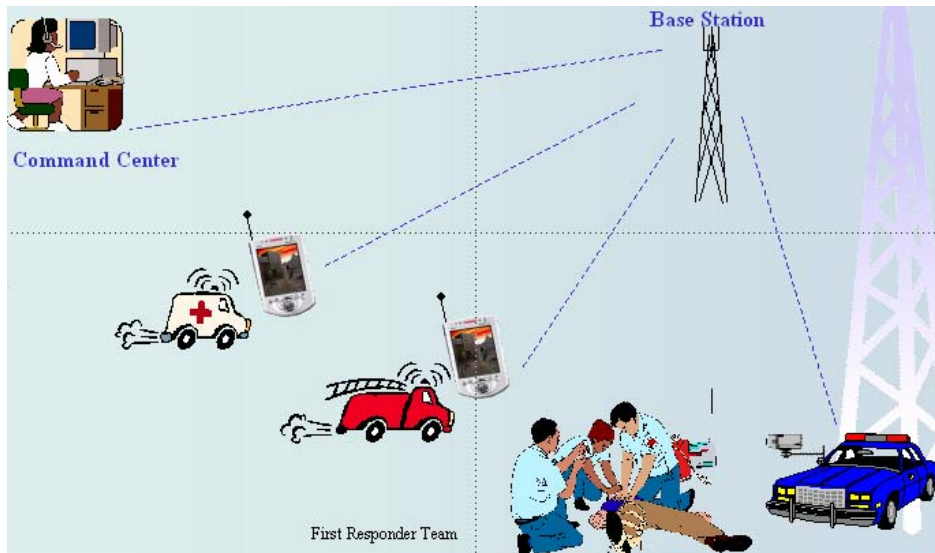

Medical services

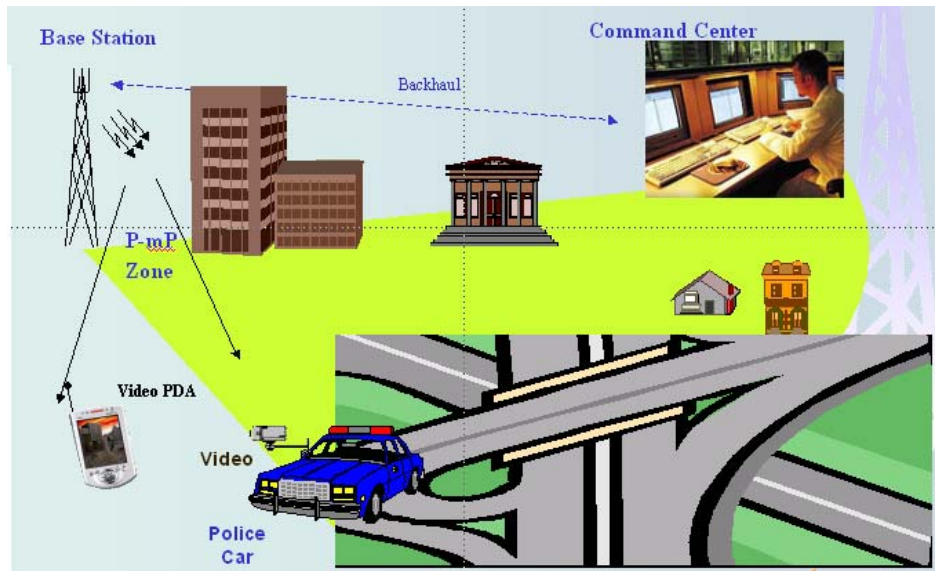

Police

Wavecom

Wavecom being a wireless broadband solutions provider has a strategic interest in SUIT as a way to get more profound expertise in both DVB, namely DVB-RCT, and WiMAX. These technologies are envisaged to become increasingly important in the Wireless transmission playground. The development of advanced video transmitting systems based on these technologies can lead the way to provide video services in particular scenarios that Wavecom is committed to approach:

- High speed trains
- Highway coaches
- Catamaran (high speed boats, jetfoils)

6.2 Universities/Research Centre Exploitation

The SUIT project is one of the projects that play a strategic role in the growth plan of SUIT academic partners. In particular, the theoretical know-how that will be acquired in the project is of prominent value to the Laboratory, since the latter aims to build an advanced knowledge base.

Specifically, the interest of universities and research institutes in this project is twofold: on one hand, participation in this project enables both the staff and the students to improve their knowledge on the specific area of broadcasting digital television with also a multicast/unicast “flavour”, thus contributing to the development of science and technology in their countries. On the other hand, since the universities are committed to transfer technology to industry, the training with real-world problems and data acquired by students, some of whom will be working for the industry later on, is an effective way to implement this transfer. Furthermore increasing the students training in a very competitive area creates career opportunities for these students. The dissemination of results is done not only by the usual means at the international level (i.e., publishing papers in journals and conferences), but also by organising seminars at the national level, thus creating conditions for the transfer of results to the national industry. Since the universities have also links to the national regulator bodies on telecommunications, indirect contributions to standards are also done through these links. Finally, the participation of the universities in research projects at the European level contributes to increase their competitiveness at the national level, attracting students and enabling better links with the industry. By organising seminars and by publishing papers the scientific reputation of the university/research centre will be increased and will help to rise up the Universities position in the world ranking.

In order to be more specific for the larger group of partners (the academia), next is presented a more specific exploitation plans description for all the universities and institutes that belong to the consortium.

IT

IT is a non-for-profit research institution aiming at the development of Telecommunications Technologies. In addition to professors and researchers, a large number of graduate and undergraduate students are also participating in IT projects in the scope of their PhD., MSc. or final work theses. The interest of research institutions of universities like IT, in this STREP is twofold: on one hand, participation in this project enable both the staff and the students to further increase their knowledge on the specific area of Digital Television Networks and TV Signal Processing and Adaptation to heterogeneous networks and terminals, thus contributing to the development of science and technology in Portugal. On the other hand the students training in very competitive areas create career opportunities for these students. Besides, most of European countries are switching off their analog TV transmissions and therefore more high tech human resources are required to deal with the new digital concept of television. Publishing papers in journals and conferences is the most important manner to disseminate the results. However, the proposal of several patents is another way to disseminate the results taking advantage of the project links with the partners from industry. The participation of the research centres in research projects at the European level contributes to increase their competitiveness at the national level, attracting researchers and students enabling better links with the industry and operators. We should point out that IT-Aveiro premises are shared by PTInovação and Aveiro University researches. IT has a strong connection with Portuguese industry and in particular with IT partners, i.e. the main Portuguese operator, Portugal Telecom and the top telecom manufacturer, Siemens. Furthermore, in Portugal, Aveiro University has got the top score in terms of number of patent granted per year. As mentioned above, SUIT will definitely contribute to transfer know-how and technologies to the industry and exploit patents. IT has been teaching courses to Portuguese operator about telecom subjects. Finally, by jointly organising project seminars and by publishing papers the scientific reputation of the research institution increases.

IBBT

IBBT's primary mission is to gather highly competent human capital, and to perform multidisciplinary research at the disposal of the business community and the Flemish government. In this research all aspects necessary for enabling the development and exploitation of broadband services are attended to on the scientific/technical and legal as well as the social level. Through investment in multidisciplinary research, IBBT wants to empower Flanders as an authoritative and international player in the future information society. The exploitation and valorisation strategy of IBBT is based on:

- Realizing demand-driven research programs, focused on the development of generic knowledge (mid-term knowledge).
- Executing company specific R&D projects with and initiated by the industry and the services sector, as well as participating in European research programs.
- Providing a broadband testing environment.
- Creating and supporting a forum in view of a wide network of all economic, scientific and societal actors involved.

This has resulted in plural projects with large companies and SMEs, such as Alcatel, Siemens, Belgacom, Public Flemish Broadcast station (VRT), private broadcast stations and production houses (VMM, Videohouse), Concentra, Agfa, Barco, Telindus, Televic, etc. Furthermore, IBBT disseminates its knowledge via: Scientific publications; Patents; Public workshops and courses; and User committee, consisting out of companies which are informed on regular bases on the scientific progress.

UniS

The University of Surrey and the Centre for Communications Systems Research in particular, has an excellent track record in intellectual property exploitation. CCSR has developed strategic partnerships with a number of industrial partners to assist in the exploitation of research results. Once intellectual property rights for the produced work have been secured, the technology will be put forward for standardisation in collaboration with an industrial partner with a view to eventual exploitation and/or licensing of the technology. This will ensure maximum returns for the University, whilst providing a pathway for the inclusion of the developed systems and algorithms in future communication systems. A spin off company has already been established as a route for licensing university technology. The main results of the research will also be published in technical journals and conferences. Journals will include IEEE Transactions, and IEE Proceedings, while the conferences targeted include ICASSP, ICIP, and VTC.

The SUIT results will be used to benefit UniS in three ways: by obtaining income from industry, training researchers, and by enhancing our research reputation.

- *Income from industry.* There are a number of specific avenues that may be taken to exploit the work in SUIT. The first is through consultancy, via a spin-off company. A further possibility is to establish a UK government supported Knowledge Transfer Partnership with a company. Talks will be held with a company that works closely with UniS, in the area of visual collaboration, to see if the results can be exploited in that work.
- *Training researchers.* Our researchers have already benefited from SUIT by learning about fields related to their own specific area of expertise. Exchange of personnel is also seen as being an important way for our researchers to gain experience. One of our researchers has already spent time in IT.
- *Enhance research reputation.* Joint papers will be prepared and submitted to conferences. The error patterns obtained in workpackage 2 will be used in UniS research work outside SUIT, such as error robust video coding work.

URL

The Universitat Ramon Llull with its Digital TV Center will participate to SUIT project with the aim of enlarging the existing know-how and perform further research in the field of broadcasting optimisation techniques. As URL is deeply involved with local Spanish broadcasting industry, the expected results from SUIT will be transferred to local industry

though industrial contracts and licenses. Moreover SUIT will provide an excellent framework for university PhD students to develop their thesis in a highly motivating project. Finally, the scientific outcomes of the project will be disseminated to the industry and research community through international conference and journal papers.

IRT

The SUIT project enables IRT to gain information and guidance on how to deploy a combined DVB-T/WiMAX coverage scenario, especially in highly populated areas where terrestrial DVB frequencies are scarce and where interactivity (which WiMAX brings about) is of special interest to broadcasters. IRT will use this knowledge in order to advise the broadcasters and the industry when implementing a SUIT-type of service concept.

Furthermore, by carrying out WiMAX transmission tests (within but also outside SUIT) it is expected to assemble practical experience enabling IRT to evaluate new contribution networks (audio-visual content contribution via WiMAX from a field interviewer into the studio) what is amongst others of special interest of broadcasters.

UPM

UPM expects that its contribution to the SUIT project will enlarge its knowledge and experience in the areas of scalable coding, transcoding, and rate control. The results are expected to cross-fertilise with current activities and to support future initiatives in these areas. It is an intrinsic role of any University to contribute to the dissemination of the results in any possible media. The UPM will, thanks to the SUIT project, continue building its long and rich tradition in this field, focusing mainly on technical and research publications, and contributions to international standards. But besides its teaching, research and development activities, the UPM is highly interested to participate in the exploitation of the outcomes of the projects in which it is involved. This participation will depend on the type of result and each partner's contribution. The results obtained by the UPM will be used as background knowledge for other R&D projects, copyright and patent issues being properly handled through the Technology Transfer Offices of the UPM.

6.3 Activity 7.3: Exploitation Plans:

The consortium intends to demonstrate SUIT platforms in top expositions like 3GSM 2008 and IBC 2008. Besides, companies exploitation plans are:

Vitec:

- Vitec intends to exploit the SVC Codec and MDC Codec. Demonstrations in technical expositions like IBC and NAB.
- Some Codec results from SUIT can be exported/re-used to Vitec AVC Codecs specially related to High Definition.
- Constant Collaboration with IBBT as IBBT and Vitec jointly collaborate in the design and development of the SUIT MDC Codec.

R&S:

- **Control software for test set-up**
 - It is planned to validate the control software modules that control the test signal generators with potential costumers from the receiver industry. In such a case, the receiver that initiates the handover in a DVB-T/H system is the DUT. Therefore, a receiver manufacturer needs to access QoS relevant information at an internal receiver interface, and integrate the respective control software modules into their testbed control software.
- **Test streams**

- Test streams are required to provide input signals for the test signal generators of the testbed. These test streams are generated in pairs. They contain at least one service which is identical in both streams but the signalling (PSI/ SI in the respective tables) is different in both streams.
Such pairs of test streams will be generated for various bit rates in such a way that they can be used with different modulation schemes and different code rates.
- **Wireless Network Emulator**
A wireless network emulator is required to evaluate video performance over WiMAX and DVB-T/H under multipath channels. The network operators can decide parameters and configurations.
- **To summarise:**
 - Control SW for controlling test signal generators in a HO testbed;
Decision on product development after validation with potential customers;
Availability planned for early 2008.
 - Test streams for test signal generators as part of a stream library;
Availability planned for early 2008
 - Emulator as part of our equipment portfolio. It can be an option of a test equipment
Availability planned for 2008

RUNCOM:

- Network convergence solutions
- RUNCOM intends to exploit the receiver dual mode chip
- Optimize the SUIT demonstrator for mobile video surveillance
- Playout equipment to assess the receiver dual mode chip functionalities

Wavecom:

- Wavecom intends to create and exploit a standalone integrated version of the WiMAX/DVB-T/H dual access gateway.

7 Conclusions and Future Plans

SUIT could play an important role, not only because of its technical merits but also due to its bandwidth efficient techniques that would help drop down the cost of licensing spectrum. It would essentially help to make the mobile experience, the one with always-on, offering an appropriate high-speed access to deploy media-rich applications, much more reliable and enjoyable to watch.

More emphasis will be put on exploitation plans of each partner and ascertain the effective dissemination of results and exerting the influence within the standardization bodies through successive submittal of technical contributions.

Of major importance is the experimental Demonstrator at the end of SUIT project as the platform for demonstrating assets developed on selected applications to be decided on within WP7.

The collaborative nature of IST programme and in SUIT consortium is very important and helpful in the attempt to create a wide consensus among potential users of SUIT results (Service Providers, System Integrators and Broadcasters and ISPs), and to try persuade the adoption of the results. The SUIT consortium as a whole and each member should pursue an active role in the participation in relevant seminars, cluster activity, concertation days, exhibitions, publishing technical papers and active participation in standardisation bodies. The SUIT consortium, from the outset, is working closely to provide valuable inputs to standard bodies and participate actively in working groups.

Two test scenarios will be evaluated for potential deployment at the end of SUIT project

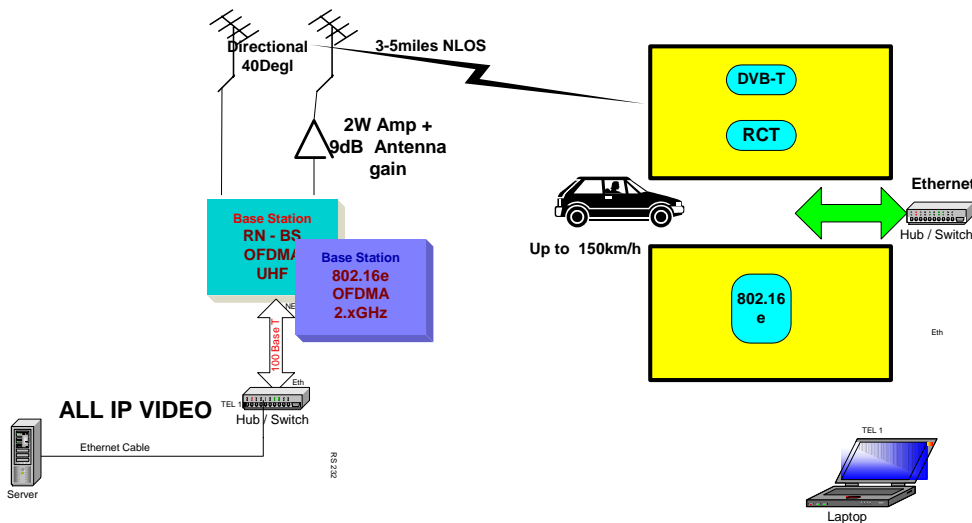

Test scenario 1 in both UHF and 2.3GHz band

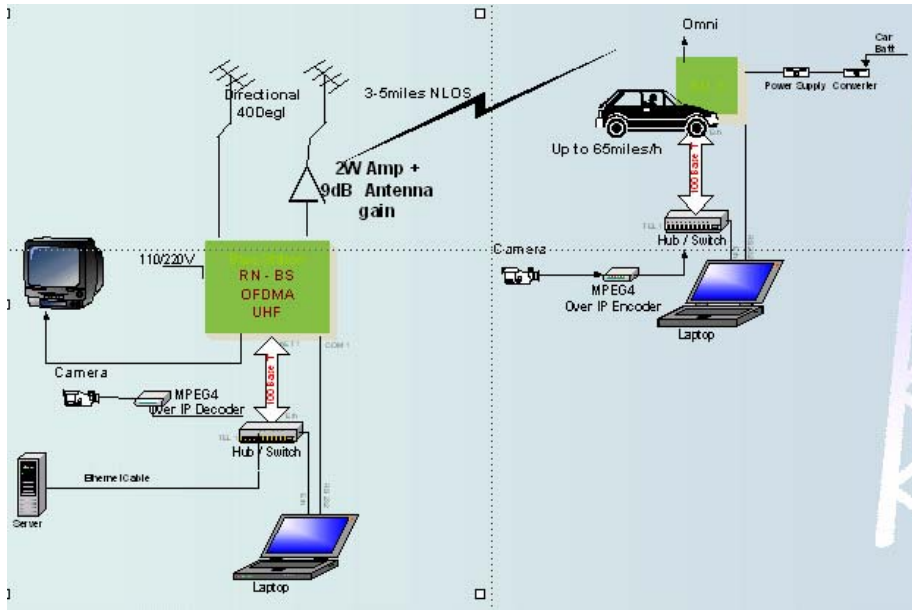

Mobile video surveillance in UHF band